



PROVEN PERFORMER

Vended Laundry

SFNNXA (front loading washer - White) SFNNXA-SS (Stainless Steel)

Front loading washer features

- Improved suspension with new out-of-balance logic
- High spin speed up to 1,200 rpm removes more water from clothes, speeding up drying cycles and lowering dryer energy usage
- Heavy-duty construction with stainless steel wash bowls
- A pump drain allows our front load washers to be installed adjacent to or replace top load washers with no special plumbing
- Redesigned supply dispenser features four compartments and automatically dispenses as needed for a complete wash
- Single slot electronic multi denomination coin drop for versatility and accuracy
- Digital display and countdown

Options

- Plinths for easy loading, 150mm high and 300mm high steel bases are available
- Credit Card Activation



Supporting Smart Card, Tap & Go, Mag Stripe



STAINLESS STEEL WASHER DRUM

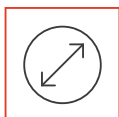

LARGE DOOR OPENING



LOW WATER CONSUMPTION



LOW ENERGY CONSUMPTION



COMPACT DESIGN

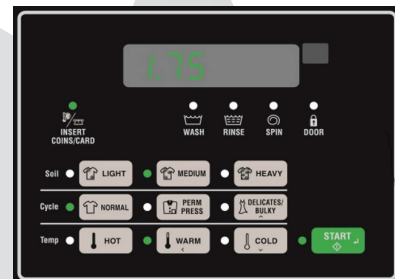

SFNNXA



SFNNXA-SS (Stainless steel)

Controls

Quantum™ Gold

In addition to its network capabilities and remote off-site management features, Quantum™ Gold offers additional owner and customer benefits such as PC programming and machine audit capabilities, as well as time-of-day pricing, a “lucky cycle” for loyal customers and the ability to interface with the store owner’s payment systems.

Cycle modifier keys create additional profit opportunities for store owners.

| SFNNXA SFNNXA (Stainless steel) | |
|--|-------------------------------|
| Type | Front Loading Washer |
| Control | Quantum Electronic |
| Control location | Front |
| Drum | |
| Capacity kg | 9.5 kg |
| Cylinder volume litres | 96.8 Lt |
| Width mm | 683 |
| Depth mm | 704 |
| Height mm | 1126 |
| Drum speed | |
| Spin speed G-Force | 440 |
| Spin speed rpm | 1200 |
| Motor | |
| Motor size kW | Variable speed induction 0.67 |
| Cabinet | |
| Cylinder finish | Stainless steel |
| Colours | White or Stainless steel |
| Door type (solid/window) | Window |
| Water temperatures | 3 |
| Operation | |
| Cycles | Up to 30 programmable |
| Water consumption per cycle litres | 44.3 |
| Water pressure kPa | 140/830 kPa |
| Cycle indicator lights | Digital display |
| Power | |
| Electrical requirements (voltage/Hz/Ph) | 240/50/1, 6 amp |
| Transport data | |
| Net weight kg | 122 |
| Shipping weight kg | 132 |
| Dimensions H×W×D mm | 1126×683×704 |
| Packing dimensions H×W×D mm | 1156×737×832 |
| Agency approvals | |
| Available agency approvals | SAA Electrical |

Dimensions

Front Loading Washer

| | A | B | C | D | E | F | G | H | I | J |
|---------------|-----|------|-----|-----|-----|-----|----|-----|----|-----|
| SFNNXA | 610 | 1126 | 813 | 938 | 371 | 683 | 52 | 704 | 40 | 333 |

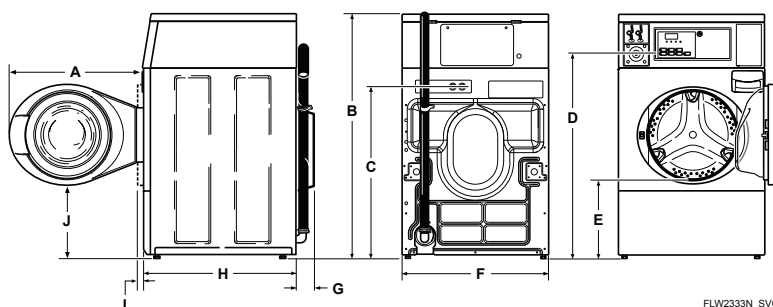

FLW2333N_SVG

All measurements are in mm. *With levelling legs turned into base.



